



**AFRISO sp. z o.o.**

Szałsza, ul. Kościelna 7

42-677 Czekanów

Poland

Phone +48 32 330 33 55

[zok@afiso.pl](mailto:zok@afiso.pl)

[www.afiso.pl](http://www.afiso.pl)

## Installation and operation manual

### Pump assemblies BPG

BPG 240

BPG 241



- + Read the manual before using the device!
- + Pay attention to all information regarding safety!
- + Keep the instruction manual!

# Table of contents

1	Explanations to the installation and operation manual.....	3
1.1	Safety messages and hazard categories.....	3
2	Information on safety.....	4
2.1	Intended use of the device.....	4
2.2	Quality control.....	4
2.3	Qualification of personnel.....	4
2.4	Personal protective equipment.....	4
2.5	Modifications to the product.....	4
2.6	Using additional parts and accessories.....	4
2.7	Liability.....	4
3	Product description.....	5
3.1	Construction.....	6
3.2	Dimensions.....	8
3.3	Operation.....	9
3.4	Scope of delivery.....	10
4	Transport and storage.....	10
5	Examples of application schemes.....	11
6	Technical data.....	14
7	Approvals.....	15
8	Installation and commissioning.....	15
8.1	Wall mounting.....	15
8.2	Hydraulic connection.....	16
8.3	Electrical connections.....	17
8.4	Use of the actuator and the mixing valve.....	18
8.5	Filling and venting.....	21
9	Maintenance.....	22
10	Decommissioning, disposal.....	22
11	Return.....	22
12	Warranty.....	22



# 1 Explanations to the installation and operation manual

Installation and operation manual is an important part of the scope of delivery. That is why we recommend:

- ▶ Read the installation and operating instruction before installing the device.
- ▶ Keep the installation and operating instruction for the entire life of the device.
- ▶ Hand over the installation and operating instructions to any subsequent owner or user of the device.

## 1.1 Safety messages and hazard categories

**DANGER** Specifies the type and source of a threat.



- ▶ Describes what to do to avoid a hazard.

Threats have three levels:

Danger	Importance
<b>DANGER</b>	DANGER indicates a hazardous situation, which, if not avoided, will result in death or serious injury.
<b>WARNING</b>	WARNING indicates a potentially hazardous situation, which, if not avoided, can result in serious injury or equipment damage.
<b>NOTICE</b>	NOTICE indicates a hazardous situation, which, if not avoided, can result in equipment damage.



## **2 Information on safety**

### **2.1 Intended use of the device**

Pump assemblies BPG are designed for use only in closed heating and cooling systems, where the medium is water or a mixture of water and glycol with a maximum concentration of 30%. BPG 240 assembly is used to pump the medium from the source directly to the receiving installation. BPG 241 assembly is used to pump the medium from the source and to regulate its temperature.

Any other use than that indicated in point 2.1 is forbidden.

### **2.2 Quality control**

Construction of pump assemblies BPG complies with the current state of the technical standards regarding safety. Each device is checked for safety before shipment.

- ▶ The product should only be used if it is in a qualified technical condition. Read the instructions for assembly and use as well as observe the relevant safety regulations.

### **2.3 Qualification of personnel**

The device may only be installed, commissioned, shut down and disassembled by suitably qualified and trained personnel. To avoid errors in installation, operation, and accidents during exploitation, ensure that all persons are familiar with its operation and with chapter 2 of this manual.

### **2.4 Personal protective equipment**

Always wear the required personal protective equipment. When working with the product, it must also be taken into account that hazards may occur at the place of use that are not directly caused by the product.

### **2.5 Modifications to the product**

Changes and modifications conducted by unauthorized persons may cause hazards and are prohibited for safety reasons.

### **2.6 Using additional parts and accessories**

Improper additional parts and accessories may damage the device.

- ▶ Use only original spare parts and accessories from the manufacturer.

### **2.7 Liability**

The manufacturer is not responsible for direct damages or their consequences resulting from inaccurate reading of assembly and usage instructions and recommendations.



The manufacturer and the company selling the device are not responsible for damages and costs incurred by the user or third parties using the device, in particular for damage resulting from improper use indicated in chapter 2.1 of assembly and use instructions, improper or faulty connection or maintenance and noncompliant operation with manufacturer's recommendations.

AFRISO sp. z o.o. makes every effort to ensure that the information materials do not contain errors. If errors or inaccuracies are found in the following installation and operation instructions, please contact: [zok@afriso.pl](mailto:zok@afriso.pl), tel. +48 32 330 33 55.

### 3 Product description

Pump assemblies BPG come in two models: direct BPG 240 and with rotary mixing valve BPG 241. In all models, all fittings and pipes, are in EPP insulation. The shut-off valves and mixing valve are made of brass. The return pipe is made of electrophoretically painted black copper. This coating prevents moisture from condensing on it during installation of the assembly in the cooling system.

Special paths have been grooved on the back of the insulation for routing cables and wires from the temperature sensors.

The most important components of BPG assemblies are:

- shut-off valves with thermometers built into the knobs,
- circulating pump AFRISO APH 161,
- rotary mixing valve with 3-point electric actuator ARM 141 (BPG 241 assembly only),
- shut-off valve before the pump (BPG 240 assembly only),
- check valve (built into the ball of the shut-off valve on the return connection).



### 3.1 Construction

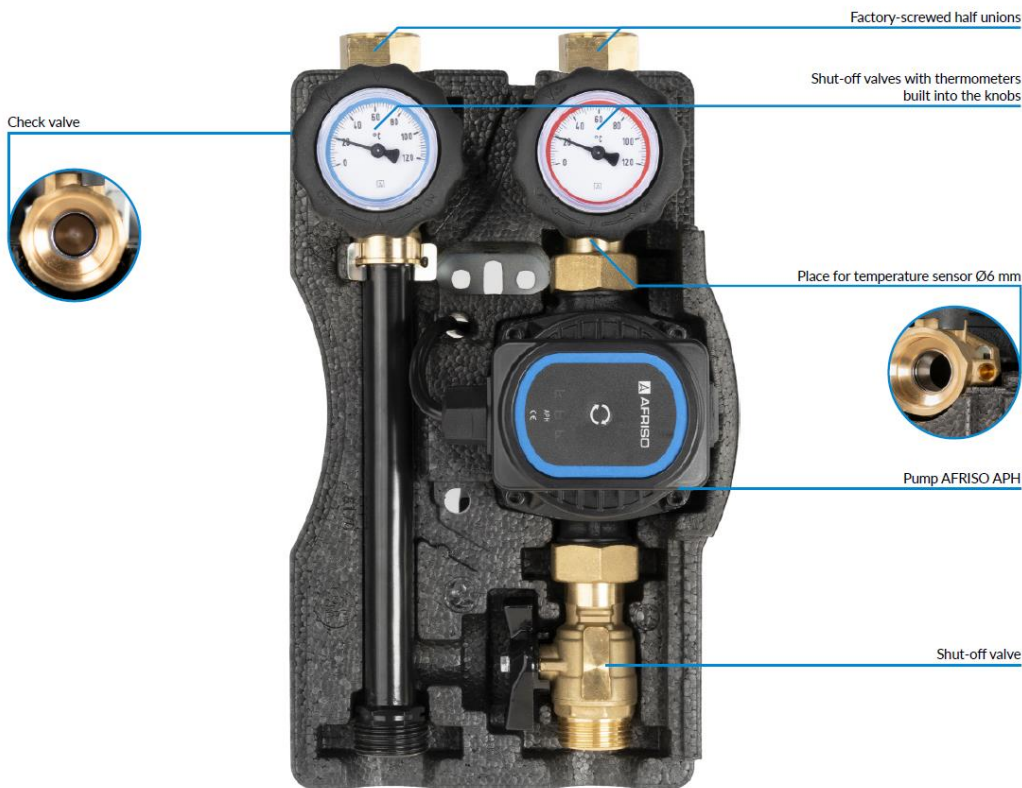

Figure 1: Construction of the BPG 240 pump assembly

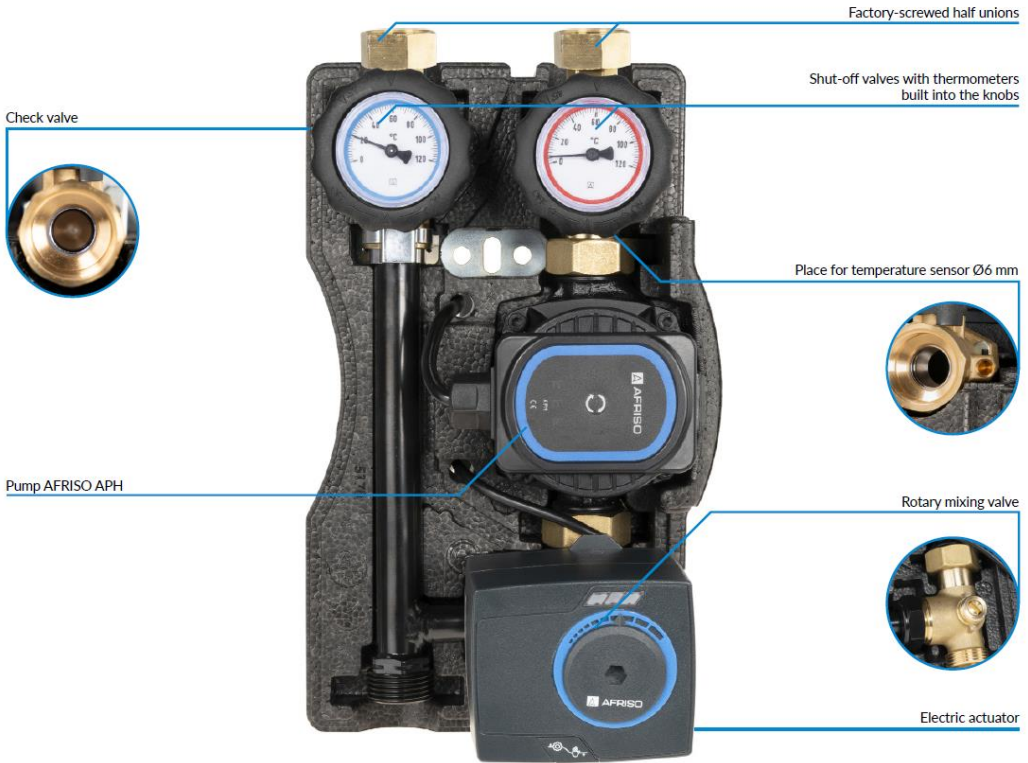
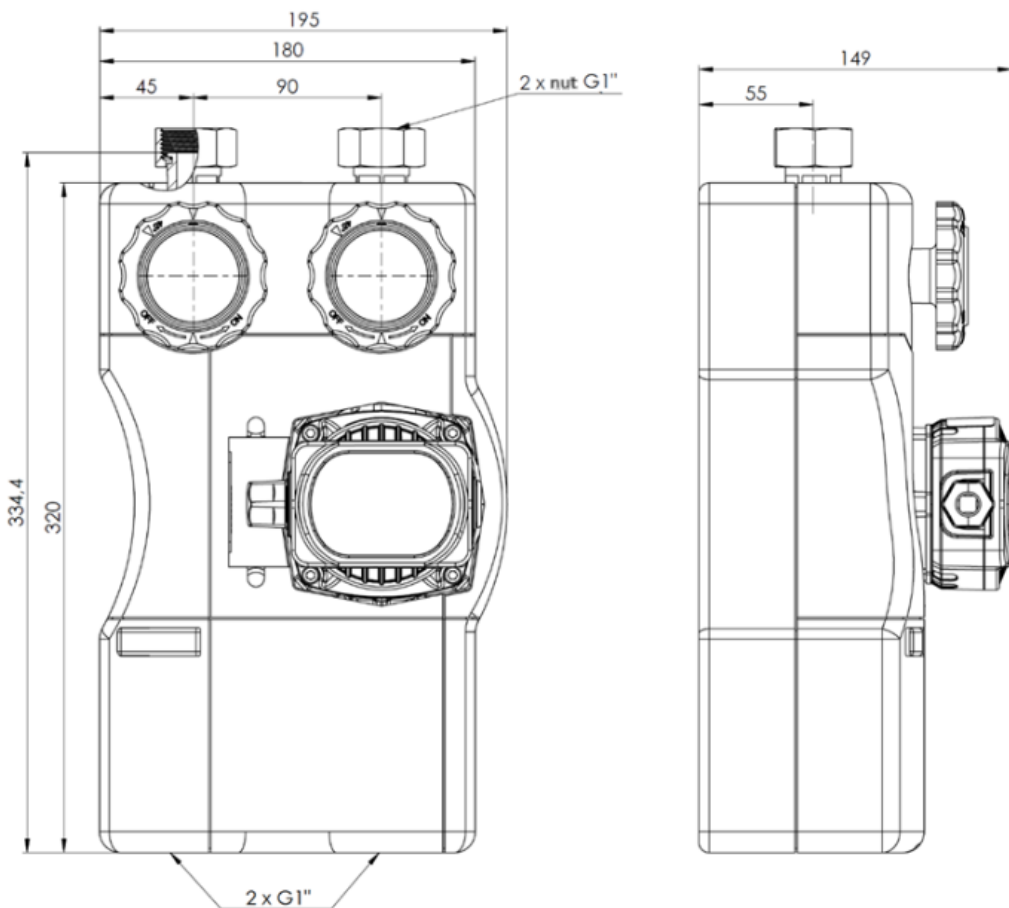

Figure 2: Construction of BPG 241 pump assembly



### 3.2 Dimensions





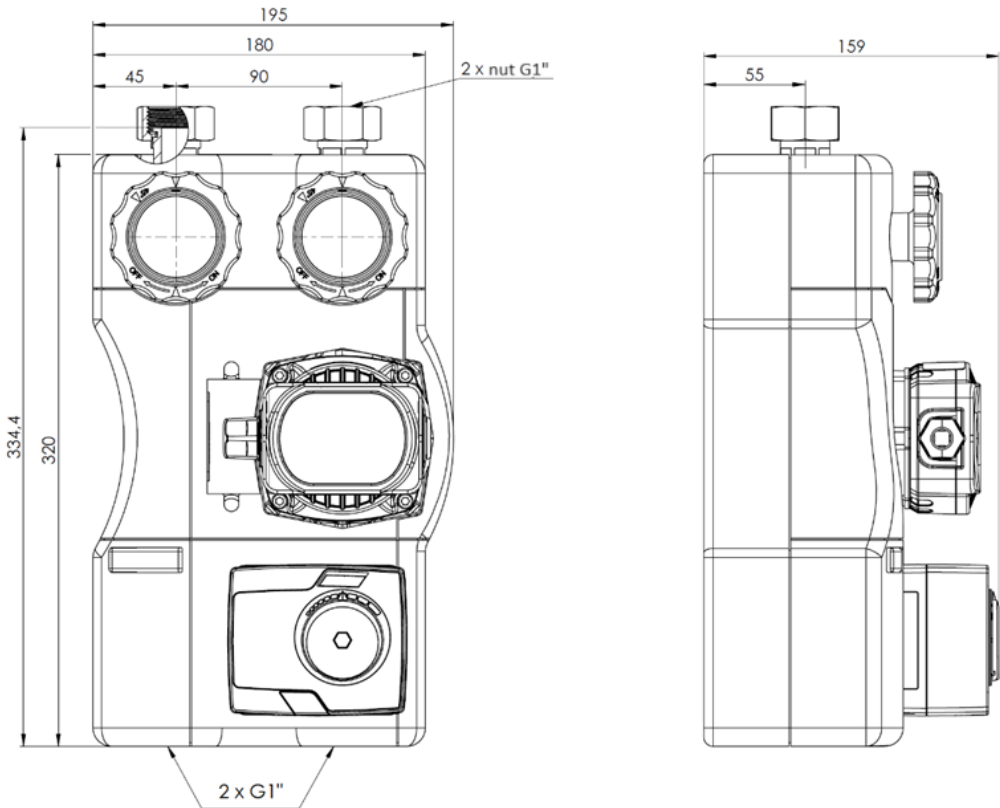

Figure 3: Dimensions of BPG assemblies

### 3.3 Operation

BPG assemblies are used to pump the medium from the source / buffer tank to the heat / cooling emitters. The assembly with a mixing valve additionally makes it possible to regulate the temperature of the medium. Thanks to a 3-point electric actuator mounted on the valve, this process can be carried out automatically after connecting to a suitable controller.

The circulating pump APH 161 ensures adequate flow in the receiving installation, thanks to 9 programmed modes of operation. More information on setting up and operating the pump can be found in the instruction manual included in the package.

Shut-off valves with built-in thermometers located on the connections enable shutting off the receiving installation (e.g. for maintenance) and controlling the temperature of the medium at each connection. A check



valve built into the ball of the shut-off valve on the return prevents backflows. Turning the knob 45° to the right forces the check valve open to facilitate filling the system. The valve located on the supply has a special pocket for a temperature sensor with a maximum diameter of 6 mm.

The shut-off valve located before the pump in the direct assembly facilitates maintenance and possible replacement of the pump.

### 3.4 Scope of delivery

The scope of the delivery of the BPG assembly include:

- BPG assembly with APH 161 pump,
- screws with wall plugs for wall mounting,
- installation and operation manual of the BPG assembly,
- ARM 141 electric actuator (BPG 241 group only).

## 4 Transport and storage

---

**WARNING** Possibility of damage to the device during improper transport.



- ▶ Do not throw the device.
  - ▶ Protect against water, moisture, dirt and dust.
- 

**WARNING** Possibility of damage during incorrect storage.



- ▶ Store the device in a dry and clean room.
  - ▶ Protect against water, moisture, dirt and dust.
-



## 5 Examples of application schemes

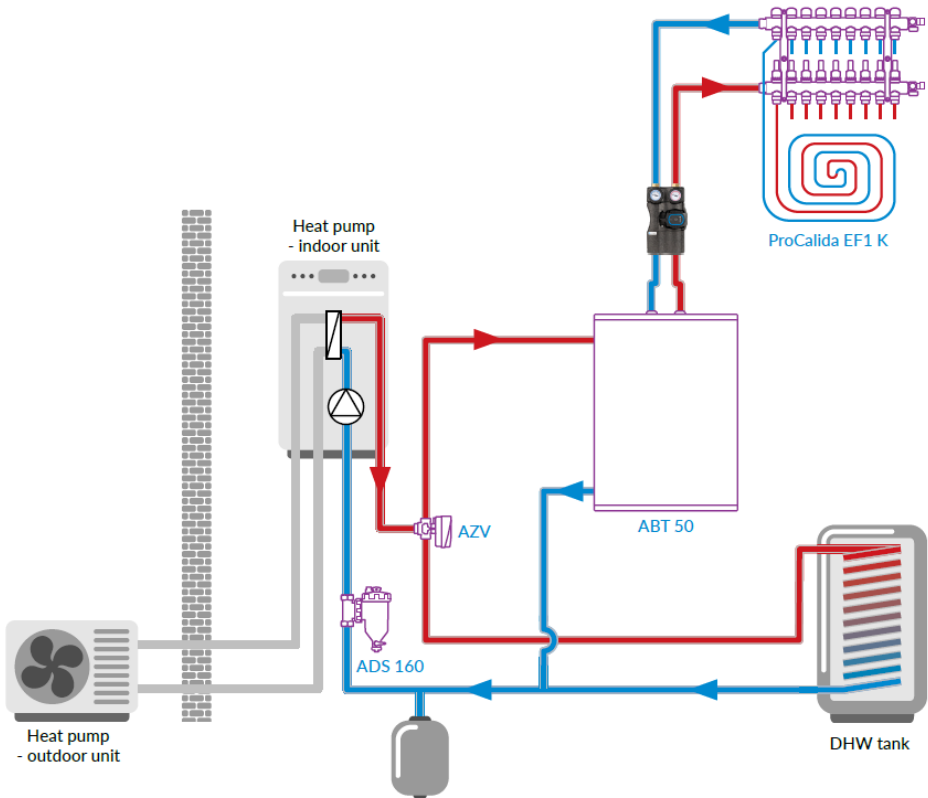

Figure 4: BPG assembly mounted on the wall in a surface heating system with a heat pump\*

\*buffer tank ABT 50 has 125 mm connection spacing

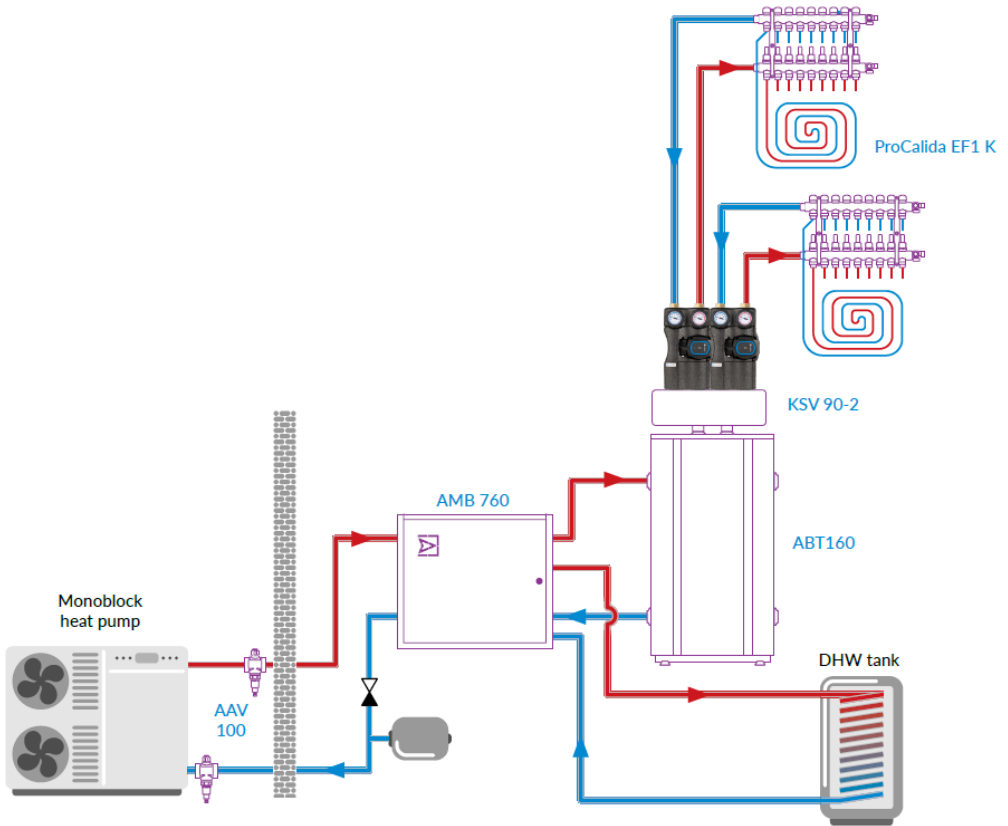

Figure 5: BPG assemblies mounted on a KSV 90-2 boiler manifold in a surface heating system with a heat pump

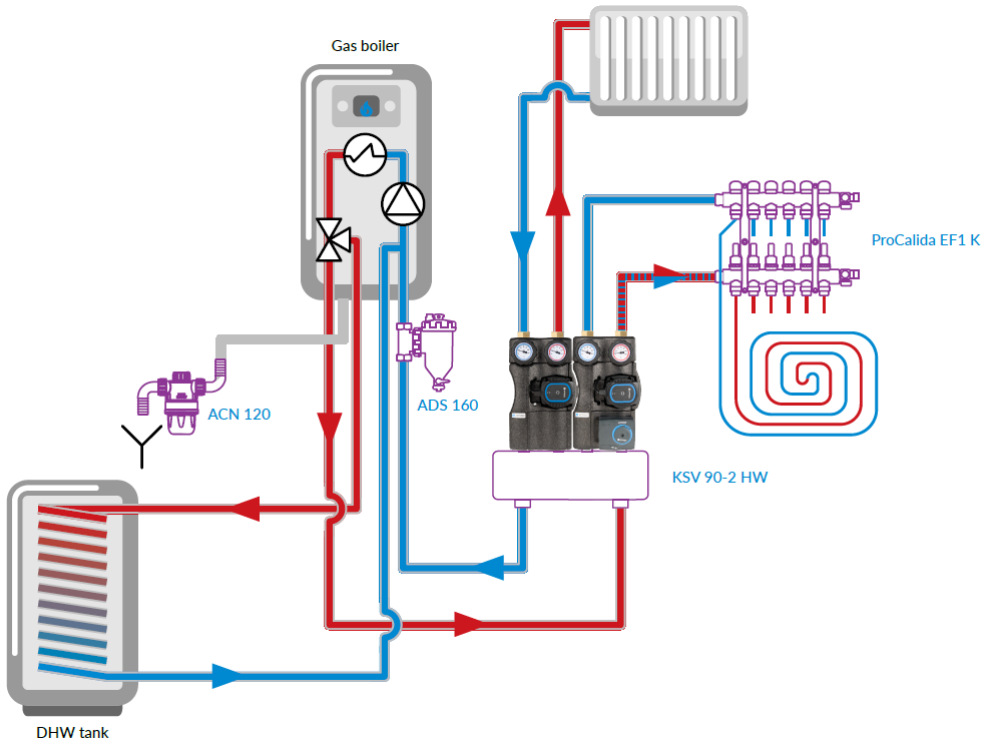

Figure 6: BPG assemblies mounted on a KSV 90-2 HW boiler manifold with integrated hydraulic separator in a mixed system with a gas boiler



## 6 Technical data

Table 1: Technical data of BPG assemblies

Parameter/part	Value/material
<b>General specification</b>	
Working pressure	max 10 bar
Working temperature	max 110°C
Kvs of the assembly	4,5 m <sup>3</sup> /h (BPG 240) 3,6 m <sup>3</sup> /h (BPG 241)
Flow	max 2,1 m <sup>3</sup> /h (BPG 240) max 2,0 m <sup>3</sup> /h (BPG 241)
Transferred power*	BPG 240 max 12,2 kW (at $\Delta T=5$ K) max 36,6 kW (at $\Delta T=15$ K) BPG 241 max 11,6 kW (at $\Delta T=5$ K) max 34,8 kW (at $\Delta T=15$ K)
Installation connections	nuts G1"
Source connections	G1"
Connection spacing	90 mm
Pipe size	DN20
Insulation	EPP (coefficient $\lambda = 0,036$ W/(m·K))
Return pipe material	electrophoretically painted black copper
Medium	water or a mixture of water and glycol with a maximum concentration of 30%
Circulating pump	AFRISO APH 161 15-7/130 mm, with a 1,6 m wire
Electric actuator	ARM 141, 5 Nm, 120 sec., 3-point
<b>Electrical parameters of the pump and actuator</b>	
Power supply	230 V AC, 50 Hz
Pump power	4 ÷ 45 W
Actuator power consumption	2,5 ÷ 4 VA

\*- may change, depending on the hydraulic resistance on the system



## 7 Approvals

Pump assemblies BPG subjects to the Pressure Directive 2014/68/EU and in accordance with art. 4.3 (sound engineering practice) are not CE marked.

The circulating pump included in the product equipment has a declaration of conformity, which is available on the website: [www.afriso.pl](http://www.afriso.pl).

The electric actuator included in the equipment of the assembly with the mixing valve BPG 241 has a declaration of conformity, which is available on the website: [www.afriso.pl](http://www.afriso.pl).

## 8 Installation and commissioning

The installation location of the BPG assemblies must be protected from the weather. The storage tank must not be installed outdoors. Pump assemblies can be installed in any room protected from temperatures below 5°C. They are designed to be hung on the wall in vertical or horizontal orientation.

Before installation, check that the wall on which the assemblies and accompanying equipment (e.g. boiler manifold KSV 90 AFRISO) are expected to be mounted is sufficiently strong.

### 8.1 Wall mounting

---

**WARNING** Possible damage to existing installations.



- ▶ When drilling into walls, take special care not to damage electrical cables or other existing piping.
- 

On the selected straight wall, mark the place provided for the wall plugs, so that they coincide with the holes. Drill holes in the wall and place in them the wall plugs that are part of the delivery. Hang the assembly on wall plugs. Then check the correct leveling with a spirit level.

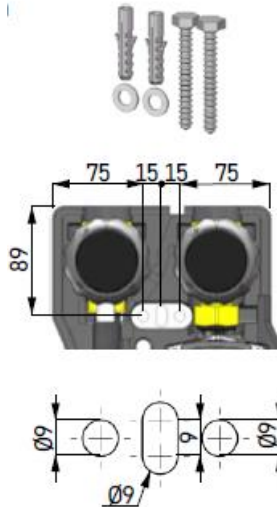

Figure 7: Location of mounting holes. One or two screws can be used as needed

When installing several BPG assemblies with KSV 90 boiler manifold or KSV 90 HW boiler manifold with hydraulic separator, the whole set can be fixed to the wall using only the hangers of the KSV boiler manifold (included in the delivery items). However, if the set is not completely stable, the BPG pump assemblies should also be fixed to the wall.

## 8.2 Hydraulic connection

### WARNING



#### No possibility of swapping the supply pipe with the return pipe.

- ▶ The construction of the pump assemblies does not allow you to swap the locations of the supply with return. Special attention should be paid to this when initially configuring the installation.
- ▶ It is not possible to directly install BPG assemblies with AFRISO KSV 90-3 boiler manifold on AFRISO ABT 160 buffer tank.

Before connecting the assembly to the heating / cooling system, the installation should be thoroughly flushed, paying special attention to the removal of residues from soldering, pipe cutting, threading, etc. For additional protection against corrosion and contamination, it is recommended to use corrosion inhibitor BCI AFRISO and dirt separator ADS AFRISO in the installation.

The pump assembly can be mounted vertically and horizontally. During installation, pay attention to the direction of the medium flow, which is marked on the pump housing. The receiving installation



should be connected to the assembly through G1" nuts. The source should be connected to G1" threads. When using boiler manifold KSV 90 AFRISO or boiler manifold with hydraulic separator KSV 90 HW AFRISO, the corresponding gaskets are included in the delivery of the manifold.

### 8.3 Electrical connections

#### DANGER



**Mains voltage 230 V AC can cause serious injury or death.**

- ▶ Do not allow the actuator housing and pump to come into contact with liquid.
- ▶ Do not touch any parts under voltage. Never connect or disconnect wires without turning off the power.
- ▶ Work on electrical circuits should be carried out by a person with the appropriate qualifications authorizations.
- ▶ Before starting any installation or maintenance work, disconnect the pump and the actuator from the power supply and protect it from being switched on again.

Observe health and safety regulations and other relevant accident prevention regulations when connecting the product to the home electrical network. Also comply with all applicable national regulations.

The circulating pump should be connected directly to the 230 V AC mains or to a controller operating at the same voltage level. The electric actuator (only in the BPG 241 assembly) should be connected to a suitable 3-point controller. If the heat / cooling source does not have a mixing valve actuator control function, e.g. the weather compensation controller BWC 310 AFRISO can be used.

The electrical wire of the actuator is detachable, which makes installation and electrical work easier. To remove the plug from the actuator, lift the lid latch lever and slide the lid off the actuator housing (Fig. 8), then unplug the plug (Fig. 9). The plug fits into the socket in one position only.



Figure 8: Removing the lid



Figure 9: ARM actuator plug

## 8.4 Use of the actuator and the mixing valve

The BPG 241 assembly is equipped with a mixing valve and an electric actuator.

The electric actuator ARM 141 operates in automatic mode (rotates the closing element according to signals from the automation) or in manual mode (rotating the closing element through the actuator mechanism using an Allen key). Switching the mode of operation is done by an operating mode change button.



*Figure 10: Actuator mode change button*

The actuator can be easily disassembled and reinstalled on the valve. To remove the actuator from the valve, press the special button on the side of the actuator housing and pull it towards you.



*Figure 11: Button releasing the mechanism holding the actuator to the valve*

In order to install the actuator on the mixing valve, set the mixing valve to "50% open", so that the center of the valve closing element is exactly in the middle, between the hot water inlet and the cold water inlet. The position of the closing element in this position is shown in Figure 12. Then slide the actuator onto the mixing valve until the actuator mechanism locks onto it.



If the valve is set in a different position, manually (using, for example, a flathead screwdriver) adjust the closing element as shown in Figure 12. If the indicator on the actuator does not indicate the center of the scale, switch it to manual operation mode, adjust the actuator with an Allen wrench so that the indicator points to the center of the scale. After placing the actuator on the valve, switch back to automatic operation mode.

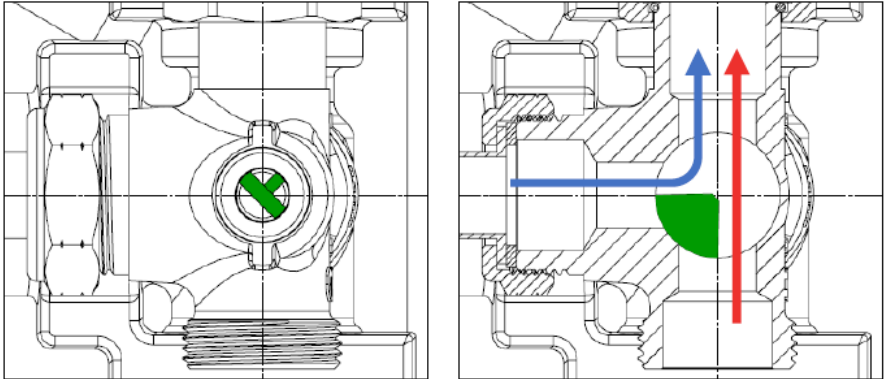

Figure 12: The position of the closing element at which the valve is 50% open

The extreme position of the valve closing element is shown in the figures below:

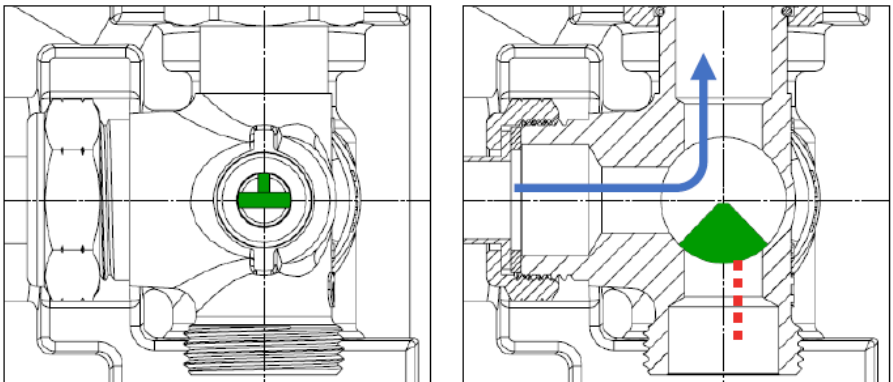

Figure 13: The position of the closing element where the medium supply from the source is cut off. All the medium returning from the receiver goes back to it

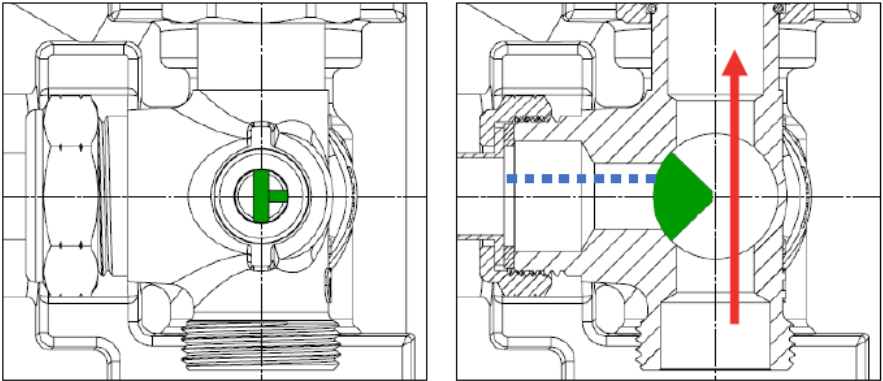

Figure 14: The position of the closing element where the flow of the medium returning from the receiver is cut off, all the medium from the source goes to the receiver

The graph below shows the flow characteristics of the mixing valve.

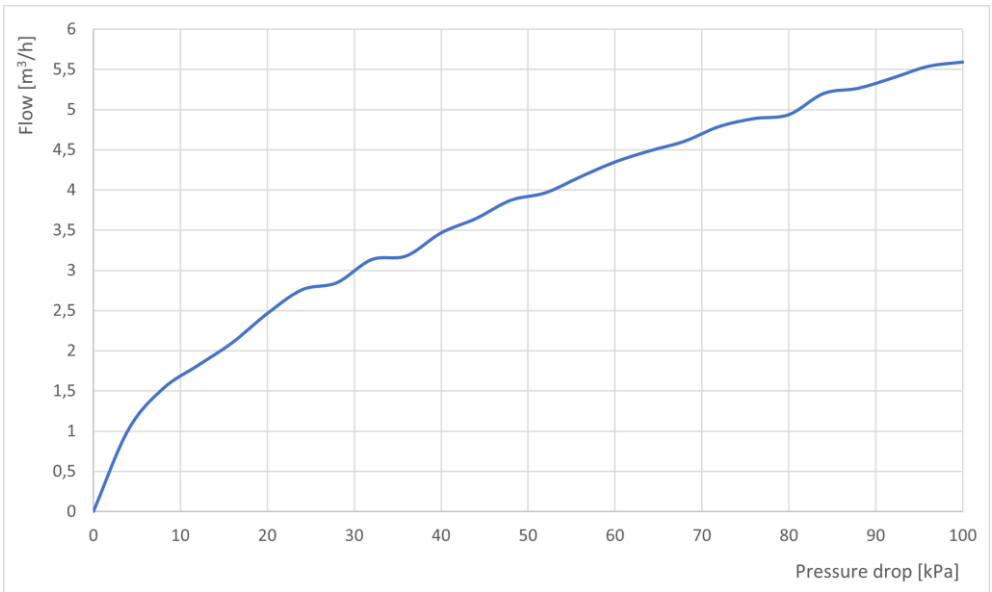

Figure 15: Flow characteristics of the mixing valve installed in the BPG 241 assembly

## 8.5 Filling and venting

After completing the installation of the assemblies and the rest of the installation, fill it with medium. To fill the installation, use water or a mixture of water and glycol with a maximum concentration not exceeding 30%. During filling, ensure that the installation is properly vented. Also, remember to fill the installation slowly with a small stream of medium, so as not to damage the components of the installation and to reduce the amount of air remaining in the installation after filling.

When filling the system, force open the check valve located in the ball of the shut-off valve on the return (with a blue thermometer). To do this, turn the knob  $45^\circ$  to the right (this position is marked on the knob). The figures below show how the check valve works depending on the position of the knob.

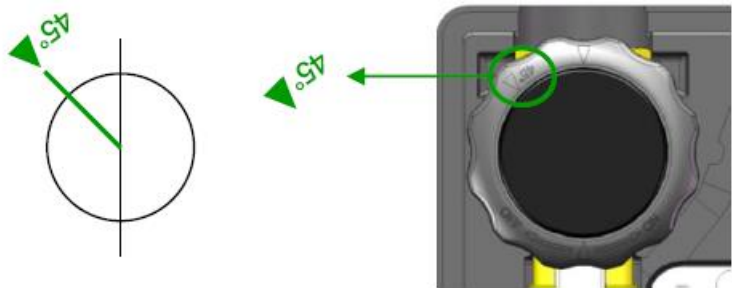

Figure 16: Initial position of the valve. The check valve in this position operates normally

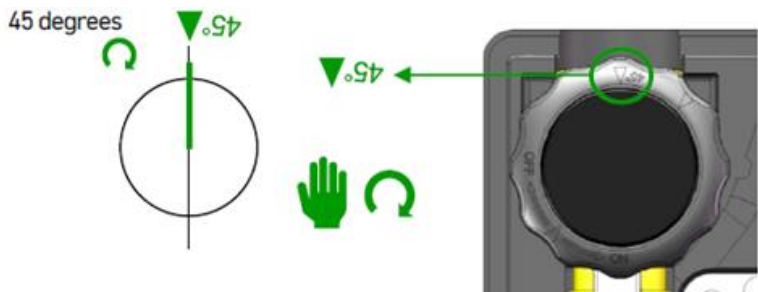

Figure 17: The position of the valve ball at an angle of  $45^\circ$ . In this position, the check valve is permanently open. It does not perform its function.

After finishing filling, turn the valve ball to the initial position, according to Figure 16.

The shut-off valve on the supply must be constantly open, the opening position is indicated by the arrows on the knob. If they are parallel to the pipe, there is flow through the valve, if they are in a perpendicular position, the valve ball cuts off the flow.

**WARNING****Risk of burns and electric shock.**

- ▶ Hot water burns can occur during installation and maintenance work. Before starting installation work, make sure that the installation has cooled down.
- ▶ Do not touch piping, which can be very hot and cause burns.
- ▶ Do not touch any parts under voltage. Never connect or disconnect wires without turning off the power.
- ▶ Do not expose the actuator and circulating pump to water.

## 9 Maintenance

Periodically, at least once a year, check the tightness of the connections of the installation with pump assemblies, and carry out a visual inspection of the condition of the assemblies for mechanical damage and corrosion.

## 10 Decommissioning, disposal



1. Disconnect the power supply to the pumps and the actuator.
2. Dismount the device.
3. To protect the environment, this product must not be disposed together with normal household waste. Dispose of the product in accordance with the local directives and guidelines.

Pump assemblies BPG consist of materials that can be recycled.

## 11 Return

Before returning a product, please contact the manufacturer: [zok@afribo.pl](mailto:zok@afribo.pl), phone +48 32 330 33 55.

## 12 Warranty

Product warranty in accordance with the general conditions of sale and delivery.